

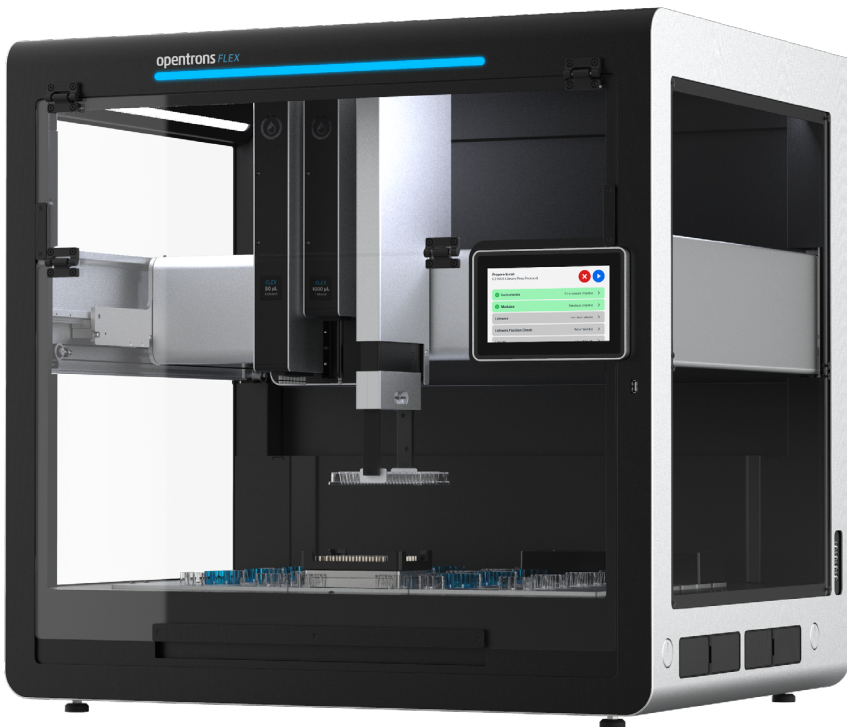

Protocol Designer

Instruction Manual



Opentrons Labworks Inc.

December 2024

Table of Contents

About Protocol Designer	3
- Protocol Designer Requirements	
Create a protocol	2
- Robot and instruments	
- Modules and fixtures	
- Protocol metadata	
- Protocol overview	
- Edit protocol	
- Protocol starting deck	
- Define and add liquids	
- Protocol steps	
- Transfer steps	
- Mix steps	
- Move steps	
- Module steps	
- Magnet steps	
- Pause steps	
Edit and finalize a protocol	24
- Protocol timeline	
- Editing steps	
- Warnings and errors	
- Warnings	
- Errors	
Export protocol	28
Modify an existing protocol	28
Protocol Designer settings	29

About Protocol Designer

Protocol Designer is a no-code, web-based tool for developing protocols that run on Opentrons robots, including the Flex and the OT-2. You can use Protocol Designer to create protocols that:

- Mix and transfer liquids, including advanced pipetting techniques
- Operate Opentrons modules
- Move labware around the deck, including on and off of modules
- Pause to verify progress or access your samples

All protocol design takes place in your web browser. After creating and editing your protocol, you can export it as a JSON file and import it into the Opentrons App to run on the robot like any other protocol.

In your protocol, you'll define the hardware, labware, and liquids the robot will use during a procedure. This manual details how to use Protocol Designer to build a protocol that works for your application in four steps:

Step	Description
Protocol setup	Specify your robot, pipettes, modules, and other hardware (like the gripper)
Protocol overview	Information about your protocol, including instruments, liquids, steps, and labware on the starting deck at-a-glance
Edit protocol	Edit your protocol starting deck, define liquids, and create protocol steps
Export protocol	Save a JSON protocol file to import into the Opentrons App and run on the robot

PROTOCOL DESIGNER REQUIREMENTS

Protocol Designer requires an internet connection and is currently only supported in Google Chrome. For the best experience, use the latest version of Chrome, maximize your browser window size, and zoom out if needed.

Newly created or modified JSON protocol files created in Protocol Designer require Opentrons App version 8.2.0 or higher to run on your robot. While Protocol Designer works with JSON files previously created in earlier versions, you can't use it to create or modify Python files.

Create a protocol

ROBOT AND INSTRUMENTS

First, select the robot you're going to use. You can use Protocol Designer to create protocols that run on either the Opentrons Flex or the OT-2.

Next, add your pipettes. Select your pipette type and volume to view available tip rack options. Protocol Designer automatically shows you tips that are compatible with your chosen pipette. You will need to choose at least one tip rack for each pipette. If your protocol uses two of the same pipette, you can start with a single tip rack for both. Later, you can add tip racks to the protocol starting deck to be sure you have enough tips for all the steps in your protocol.

After adding up to two pipettes, confirm your selections. Click **Swap pipette mounts** to change pipette mounts from left to right. On the Flex, the 96-channel pipette uses both the left and right mounts.

You can add a gripper to move labware automatically on the Flex. The gripper is added to the extension mount and will be visible in the instruments section of the protocol overview.

MODULES AND FIXTURES

Protocol Designer protocols can also control Opentrons modules on the Flex or the OT-2, as shown below. Flex lets you use multiple modules of the same type, except for the Thermocycler. On the Flex, you can also customize fixtures, including the waste chute, trash bin, and staging areas, to optimize deck space.

Module	Opentrons Flex	Opentrons OT-2
Thermocycler Module	<ul style="list-style-type: none">■ 1 module only■ GEN2 only■ Slots A1 and B1	<ul style="list-style-type: none">■ 1 module only■ GEN1 or GEN2■ Slots 7 and 10
Heater-Shaker Module	<ul style="list-style-type: none">■ Up to 7 modules■ GEN1 only■ Slots A1-D1 or A3-D3	<ul style="list-style-type: none">■ Only 1 module■ GEN1 only■ Slot 1, 3, 4, 6, 7, or 10
Magnetic Block	<ul style="list-style-type: none">■ Up to 11 modules■ GEN1 only■ Slots A1-D3	Not compatible
Magnetic Module	Not compatible	<ul style="list-style-type: none">■ 1 module only■ GEN1 or GEN2■ Slot 1, 3, 4, 6, 7, 9, or 10
Temperature Module	<ul style="list-style-type: none">■ Up to 7 modules■ GEN2 only■ Slots A1-D1 or A3-D3	<ul style="list-style-type: none">■ 1 module only■ GEN1 or GEN2■ Slot 1, 3, 4, 6, 7, 9, or 10

Fixture	Opentrons Flex	Opentrons OT-2
Trash Bin	<ul style="list-style-type: none"> ■ 1 trash bin only ■ Slots A1–D1 or A3–D3 	<ul style="list-style-type: none"> ■ 1 trash bin only ■ Slot 12
Waste Chute	<ul style="list-style-type: none"> ■ 1 waste chute only ■ Slot D3 	Not compatible
Staging area	<ul style="list-style-type: none"> ■ Up to 4 staging areas ■ Slots A3–D3 	Not compatible

You can create additional space on the Flex deck by adding as many as four staging areas to slots A3–D3. This creates an additional row of slots (A4–D4).

PROTOCOL METADATA

Finally, tell us about your protocol. A unique title, description, and author details will be displayed for your completed protocol when imported into the Opentrons App and help it stand out from the others.

PROTOCOL OVERVIEW

The protocol overview summarizes details you’ve added for your protocol. A protocol metadata section at the top left includes your protocol description, author, and organization details. Click **Edit** at the top right of the section to make changes. You can also see the dates the protocol was created and exported. Modifying a protocol updates the last export date.

Heat Shock and Transfer

Edit protocol Export protocol →

Protocol Metadata Edit

Description	Heat shock for transformation, transfer, and recovery of bacterial cultures.
Organization/Author	Opentrons
Date created	December 05, 2024
Last exported	N/A
Required app version	8.2.0 or higher

Instruments Edit

Robot type	Opentrons Flex
Left Mount	Flex 1-Channel 1000 µL Opentrons Flex 96 Tip Rack 1000 µL
Right Mount	Flex 8-Channel 50 µL Opentrons Flex 96 Filter Tip Rack 50 µL
Extension Mount	Opentrons Flex Gripper

Liquid Definitions

Edit protocol to define liquids

Protocol Steps

Edit protocol to define steps

Protocol Starting Deck Metadata List On deck Off deck

Slot Detail

Location	None
Labware	None
Module	None
Fixtures	Staging area

The protocol overview shows instruments, including pipettes and the gripper, added to your protocol. In this example, a 1- and 8-channel Flex pipette are in the left and right mounts, respectively. By default, Protocol Designer adds your first 1- or 8-channel pipette to the left mount. Click **Edit** at the top right of the section to swap mounts or add, edit, or remove pipettes or the gripper.

The protocol overview also includes a preview of your protocol starting deck. The initial deck state for a protocol includes all the labware, modules, and fixtures you've added. Protocol Designer automatically adds modules, fixtures, and tip racks to deck slots. You can edit their locations on the starting deck and add labware and liquids by clicking Edit protocol. See the next section for more details.

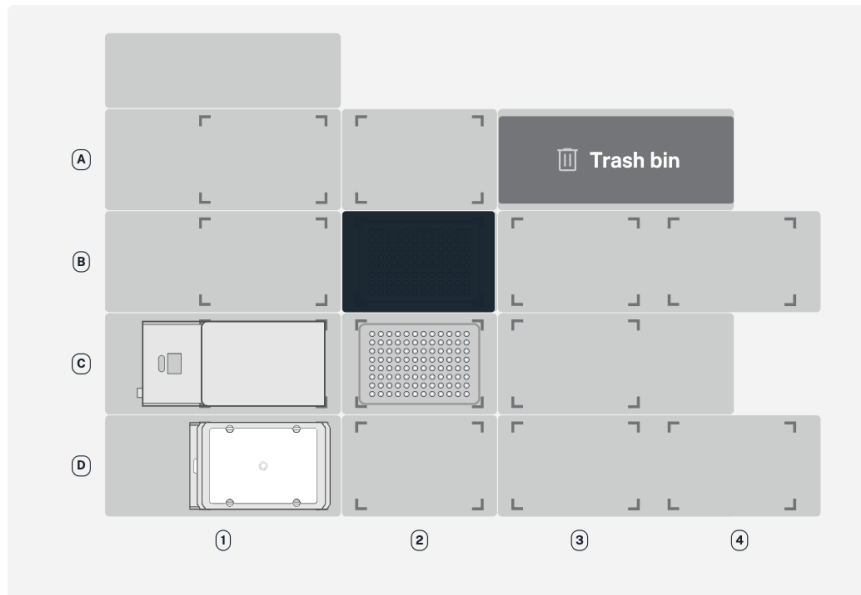

B2 Slot Detail

Liquid	None
Labware	Opentrons Flex 96 Filter Tip Rack 50 µL
Module	None
Fixtures	None

In the example above, the protocol starting deck includes a trash bin (slot A3), Temperature and Heater-Shaker modules (slots C1 and D1, respectively), two staging areas (creating slots B4 and D4), and two tip racks (one for each pipette).

Hover over each deck slot to view individual details. In the example starting deck, hovering over slot B2 shows an Opentrons Flex filter tip rack in that slot. The materials list shows the same information, including liquid definitions, at a glance. Use the toggle switch at the upper right to view any off-deck labware added to your protocol.

EDIT PROTOCOL

When creating a new protocol, click **Edit protocol** to open the protocol editor and add labware, liquids, and protocol steps. The protocol editor has two tabs: one for the protocol starting deck and another for protocol steps. This section describes editing your protocol starting deck, defining liquids, and adding different types of steps in Protocol Designer.

Protocol starting deck

The protocol starting deck tab shows the same view of the deck as in the protocol overview, but now allows you to edit. Hover over each deck slot to view slot details. You can click to edit slots and add, remove, or change hardware and labware.

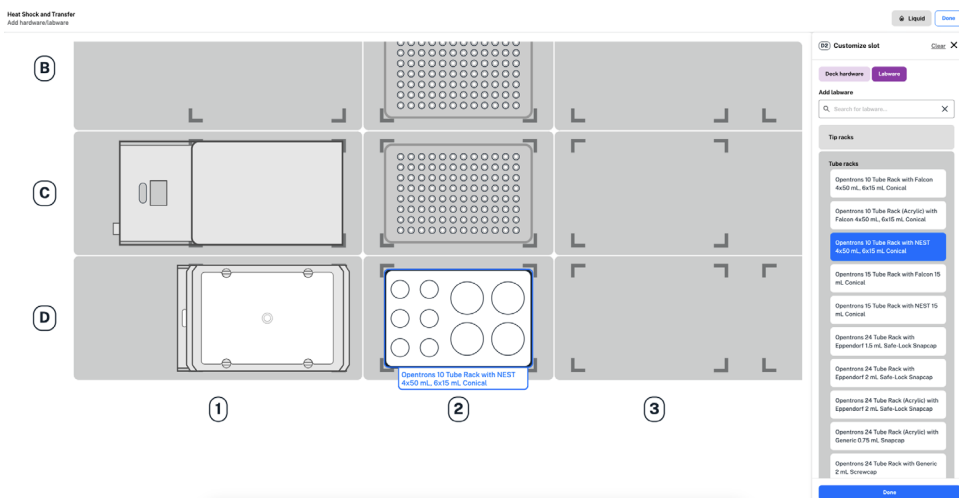

For the example deck slot D2, you can add any module or fixture allowed in this deck slot by clicking Deck hardware. Click Labware to search for or select a labware type, like a tube rack, and view available options from the Labware Library. Hover over or select an option to see the labware appear in your deck slot. At the bottom of the labware list, you can upload a JSON file to use custom labware in your protocol.

When adding labware to a module, Protocol Designer only shows recommended labware in the list of available options. You can choose to view all labware, including labware that may be incompatible with the module. If an adapter is available for the module, it will be included in the “adapter” labware category. Use the toggle switch at the upper right of the protocol starting deck tab to add any off-deck labware.

After adding labware, hover over the deck slot for additional editing options:

- Duplicate labware to add the same selection to another open deck slot.
- Rename any labware (with the exception of tip racks) to make them easier to identify throughout your protocol.
- Clear all hardware and labware from any slot.

Edit staging areas by clicking any deck slot in row 3 or 4. To add or edit a Thermocycler Module, click deck slot B1 on the Flex or 7 on the OT-2. A trash bin or waste chute is always required on the deck. On the OT-2, the trash bin is always placed in slot 12.

Define and add liquids

In the protocol starting deck tab, click **Liquid** in the top right to define liquids to use in your protocol. For each liquid, add a name and description. Choose a color for your liquid with the custom slider tools or a hex code. You can view your full list of defined liquids by clicking **Liquid** again.

On the protocol starting deck, click a piece of labware and select **Add liquid**. In the labware graphic, click and drag to select multiple wells across rows and columns. From the dropdown menu, select your liquid and enter the starting volume for each well in microliters (μL). Click **Save** for each liquid added to your labware before clicking **Done**.

Operations: 10 Tube Rack
with NEST 4x50 µL 4x15
mL Conical

Add liquid

Liquid

1.8 touch

Liquid volume by well

5000

OK

Cancel Save

Done

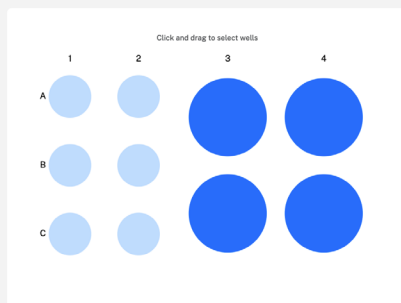

Protocol steps

The protocol steps tab includes your protocol timeline, or the steps the robot will perform in your protocol. To start, the protocol timeline includes the starting and final deck states. Return to the protocol starting deck tab to edit your starting deck state. Click Add Step to add transfer, move, mix, pause, or module-specific steps in your protocol.

Transfer steps

Transfer steps move liquid from one well or group of wells to another. Adding a transfer step opens a two-part form. In the first, select basic settings for your liquid transfer:

- The pipette to perform the transfer and the tip rack it will use.
- Source and destination labware, including wells.
- Pipette path, or motion the pipette uses to perform the transfer.
- Tip handling settings, including how often the pipette picks up a new tip and where tips are dropped.

Click **Choose wells** and click and drag to select source and destination wells. Pipette path and tip handling options are only shown if they are compatible with your other transfer settings.

Pipette Path	Well Ratio	Description
Single path	N to N	<ul style="list-style-type: none"> Aspirates enough liquid for a single transfer and repeats Select a new tip before aspirating, once at the start of the step, for each source well, or never
Consolidate path	Many-to-1	<ul style="list-style-type: none"> Multi-aspirate Aspirates from multiple wells for a single dispense Select new tips before aspirating, once at the start of the step, or never
Distribute path	1-to-many	<ul style="list-style-type: none"> Multi-dispense Aspirates enough volume from 1 well for multiple dispenses Select new tips before aspirating, once at the start of the step, or never

Protocol Designer displays a warning in the transfer form when you choose an incompatible well ratio or an empty source well.

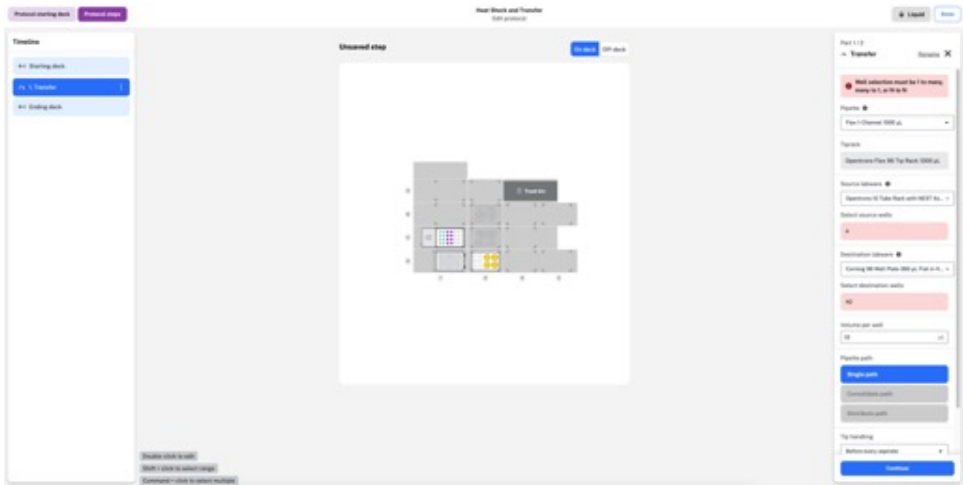

Choose a tip drop location to dispose of used tips before clicking **Continue**.

The second transfer form includes tabs for additional aspirate and dispense settings.

- Custom flow rate: the speed the robot aspirates or dispenses liquid at.
- Well order: the order the robot addresses source or destination wells in.
- Tip position: where the robot aspirates or dispenses in your labware.
- Other pipetting settings like mix, delay, blowout, and air gap.

Enter a custom value in the valid range for settings like flow rate and tip position. Default flow rates and ranges change depending on the combination of pipette and tips selected to perform the transfer. Remove your custom settings at any time by clicking **Reset to default**.

Click the default well order or tip position to open the menu and edit. Here, graphics show the order the robot moves from well to well, and where in each well the robot aspirates or dispenses liquid. You can choose a custom well order and adjust the X, Y, and Z tip positions within the valid range for your chosen labware.

Edit aspirate tip position



Change where in the well the robot aspirates from.

X position

mm

between -7.7 and 7.7

Y position

mm

between -7.7 and 7.7

Z position

mm

between 0 and 117.8

Top view

Swap view

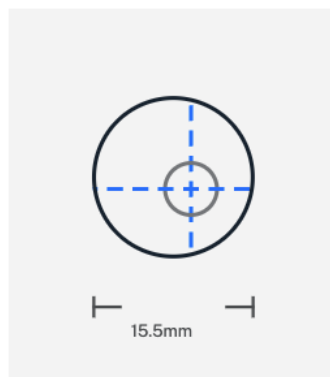

Reset to default

Cancel

Save

The default tip position value of 0 represents the middle of the well for both X and Y positions. In the example above, a positive X value moves the tip to the right within the well, a negative Y value moves the tip to the left, and a positive Z value moves the tip up towards the top of the well. As you enter custom values, the graphic changes to demonstrate the new tip position. Toggle between top and side views of the well by clicking **Swap view**.

Additional advanced pipetting settings are available in the Aspirate and Dispense tabs. These are listed in the order in which the robot performs them. Protocol Designer supports the following advanced settings:

Module	Opentrons Flex	Opentrons OT-2
Pre-wet tip	Aspirate	<ul style="list-style-type: none"> Aspirate and dispense in the source well before aspirating the transfer volume
Mix	Aspirate Dispense	<ul style="list-style-type: none"> Mix the contents of the well either before aspirating or after dispensing Customize volume and number of repetitions

Module	Opentrons Flex	Opentrons OT-2
Delay	Aspirate Dispense	<ul style="list-style-type: none"> Hold the pipette tip at a position for a defined amount of time after aspirating or dispensing Customize duration and position from bottom of well
Blowout	Dispense	<ul style="list-style-type: none"> Blow any remaining liquid out of the tip Customize location (source well, destination well, trash bin, or trash chute) Customize flow rate and tip position from bottom during blowout
Touch tip	Aspirate Dispense	<ul style="list-style-type: none"> Touch the tip to the four sides of the well to remove droplets after aspirating or dispensing Customize touch tip position from the top of the well
Air gap	Aspirate	<ul style="list-style-type: none"> Draw air into the tip after aspirating transfer volume Customize air gap volume

Some advanced settings, like mix and blowout, are not available with consolidate and distribute pipette paths to prevent sample contamination. Settings like touch tip are not available with some types of labware. Protocol Designer only allows you to select compatible settings.

Mix steps

In a mix step, the robot mixes liquid by repeatedly aspirating and dispensing. Mixing occurs in each well you select, one after the other, without moving any liquid between wells.

You can customize settings for your mix step in a two-part form. Just like in a transfer step, start by selecting a pipette, tip rack, and labware. You can customize volume per well and the number of times the robot will mix. Choose tip handling settings, or how often the robot will select a new tip, and a tip drop location before clicking **Continue**.

In the aspirate and dispense tabs, you can adjust the flow rate, well order, and tip position within the well. Available advanced settings in a mix step include a delay after aspirating or dispensing, and blowout and touch tip after dispensing. See the advanced settings table in the [Transfer steps](#) section for descriptions of each.

MOVE STEPS

Add a move step whenever you need to move labware during a protocol, either with the Flex Gripper or manually. When moving labware manually, the protocol will pause and display a message on the Flex touchscreen or in the Opentrons App. Confirm your labware move to resume the protocol.

When selecting labware for a move step, labware locations in a module are listed. In the example below, a Corning 96-well plate is placed in the Heater-Shaker Module in deck slot D1.

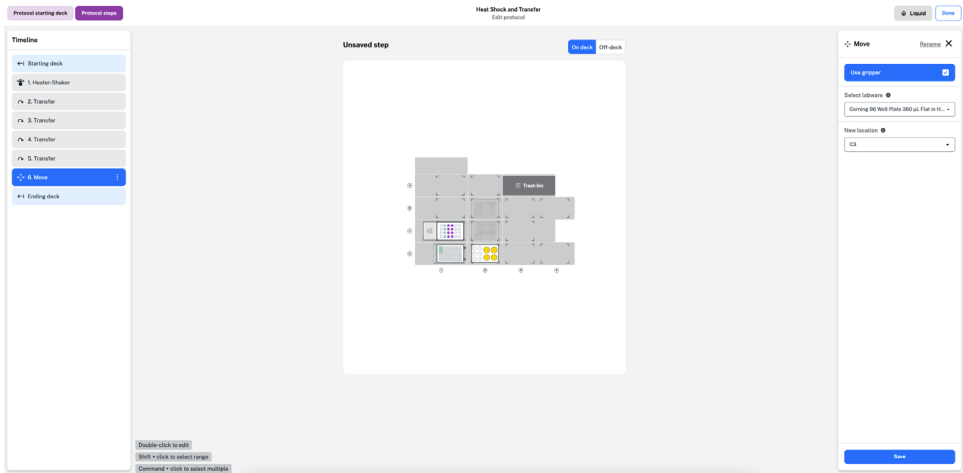

If required, labware adapters need to be added to a module before a labware move. To add an adapter, return to the protocol starting deck tab.

When moving labware to and from the Heater-Shaker Module, the labware latch must be open. Add a Heater-Shaker step to open the latch before each move step on or off of the module.

MODULE STEPS

When you add modules to the robot deck, available module steps appear in the “Add step” menu. Protocol Designer supports the use of the following modules:

Module and generation	Opentrons Flex	Opentrons OT-2
Heater-Shaker Module GEN1	✓	✓
Magnetic Module GEN1	✗	✓
Magnetic Module GEN2	✗	✓
Magnetic Block GEN1	✓	✗
Temperature Module GEN1	✗	✓
Temperature Module GEN2	✓	✓
Thermocycler Module GEN1	✗	✓
Thermocycler Module GEN2	✓	✓

You can add multiple modules of the same type only on the Flex. Only one Thermocycler can be used on the Flex and the OT-2.

Heater-Shaker Module steps

Adding a Heater-Shaker Module step to your protocol displays any labware and adapters currently on the module.

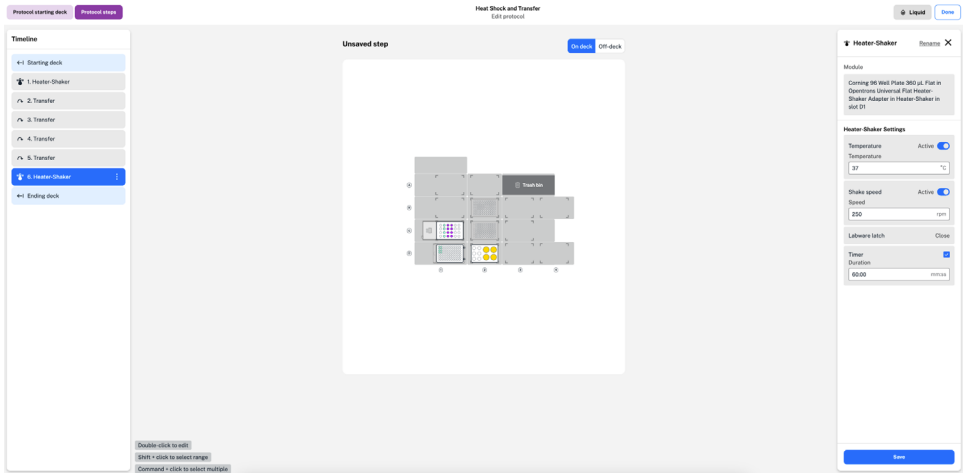

In this example, a Corning 96-well flat plate is placed on top of an Opentrons universal flat Heater-Shaker adapter. Both are on the Heater-Shaker in deck slot D1. Before moving labware to or from the Heater-Shaker, make sure that the labware latch is open. Add a Heater-Shaker step that opens the labware latch before any step that moves labware to the Heater-Shaker. Without this step, a timeline error could occur.

In the Heater-Shaker step form, set the temperature or shake functions to “Active” and enter a custom value for temperature or shake speed. The Heater-Shaker module can heat samples between 37 and 95° C, and shake samples between 200 and 3000 rpm.

Set a custom time for your Heater-Shaker step by enabling the timer. The timer will begin after the Heater-Shaker reaches the target temperature or shaking speed. Reaching a target temperature takes more time than changing the shaking speed, so you can set the Heater-Shaker to reach a target temperature while your protocol proceeds.

Pause protocol until Heater-Shaker Module GEN1 is at 37°C

Build a pause step to wait until Heater-Shaker Module GEN1 reaches 37°C before continuing to the next step.

Build a pause step later if you want your protocol to proceed to the next step while the Heater-Shaker Module GEN1 goes to 37°C

Build pause later

Pause protocol

You can choose to pause your protocol until the Heater-Shaker reaches the set temperature, or build a pause step later in your protocol. Building a pause step later allows the robot to continue your protocol while the module reaches the set temperature.

After your Heater-Shaker step, follow the same steps to deactivate the temperature and shake functions, open the labware latch, and move your labware.

Temperature Module steps

Adding a Temperature Module step to your protocol displays any labware and adapters currently on the module. Aluminum blocks or a deep well adapter can be used to add labware to the module. Click to set the module state and enter a temperature between 4 and 95 °C.

After your Temperature module step, add a second step to deactivate the module. Just like in a Heater-Shaker step, you can choose to pause your protocol until the Temperature module reaches the set temperature, or build a pause step later in your protocol.

Thermocycler Module steps

Adding a Thermocycler Module step to your protocol opens a two-part Thermocycler form. First, choose whether to change the state of the Thermocycler module or to program a profile. Changes to the module state include simple changes like opening the lid or setting an initial lid temperature, while programming a profile sets timed temperature cycles for your experiment.

Click **Change Thermocycler state** to set a block or lid temperature, or to open or close the lid. You can set the block at any temperature between 4 and 99° C and the lid at any temperature between 37 and 110° C.

Click **Program a Thermocycler profile** to choose parameters for your experiment. Start by entering values for your individual well volume and initial lid temperature. Click **No profile defined** to open the profile steps menu.

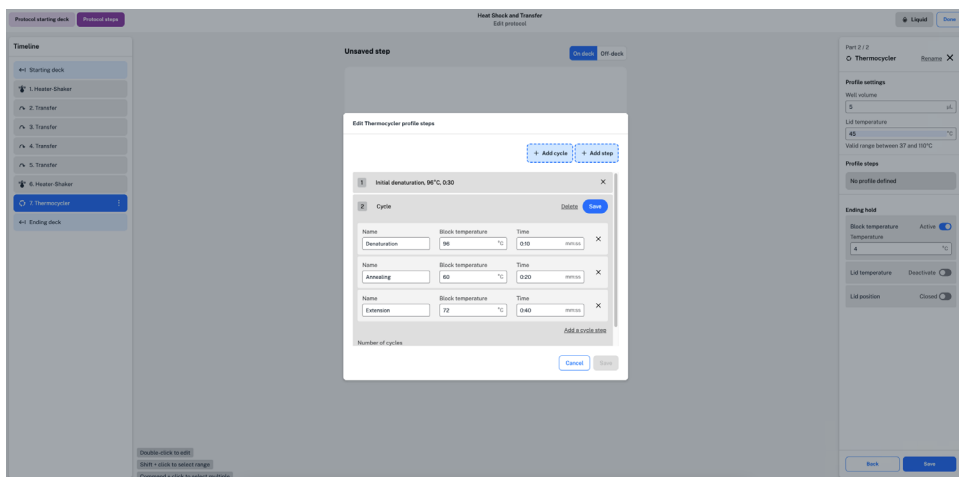

Click **Add step** to create a step, like an initial denaturation, that only needs to happen once. Choose a block temperature, time, and name for your step.

Cycles are made up of steps that are repeated a set number of times in your experiment. Click **Add cycle** to add steps to a cycle. At the bottom of the menu, enter the number of times the cycle should repeat before saving your work. Define the ending hold after all cycles and steps are complete with a block temperature, lid temperature, and lid position before saving your Thermocycler Module step.

When adding a Thermocycler Module step, labware in the module is not automatically displayed. Load labware in the Thermocycler on the Protocol starting deck or move your labware to the Thermocycler module in a move step. To move labware to and from the Thermocycler, first open the lid by clicking **Change Thermocycler state**.

MAGNET STEPS

Module steps using the Magnetic Module (GEN1 or GEN2, only on the OT-2) appear as magnet steps in the “Add step” menu. When you add a magnet step, the form shows the deck slot the module is on and any labware currently in the module.

Use the toggle switch to engage or disengage the module’s magnets. The form also lets you specify the height in the module at which the magnets will engage. Valid ranges are different for the Magnetic Module GEN1 (0 to 45 mm) and GEN2 (-2.5 to 25 mm). Swapping between Magnetic Module generations on the protocol starting deck will clear any custom engage height values you have entered.

 **All existing engage heights will be cleared** 

Switching between GEN1 and GEN2 Magnetic Modules will clear all non-default engage heights from existing magnet steps in your protocol. GEN1 and GEN2 Magnetic Modules do not use the same units.

To convert engage heights from GEN1 to GEN2, divide your engage height by 2.

To convert engage heights from GEN2 to GEN1, multiply your engage height by 2.

You may also need to alter the time you pause while your magnet is engaged.

Read more about the differences between GEN1 and GEN2 Magnetic Modules [here](#).

Don't show me again

Cancel

Continue with export

Before moving labware from a Magnetic Module, set the magnet state to “Disengage” to avoid sample disruption.

The Magnetic Block (GEN1, only on the Flex) is unpowered and cannot be controlled by the robot. Load the Magnetic Block on the protocol starting deck and use a move step to place labware in the Magnetic Block.

PAUSE STEPS

You can add a pause step in Protocol Designer to stop your protocol. Three options are available in the form to define the pause and instruct the robot how to resume your protocol.

Pause option	Description
Pause until told to resume	<ul style="list-style-type: none">■ Robot pauses the protocol until you click Resume on the Flex touchscreen or in the Opentrons App■ Add a message to display
Delay for an amount of time	<ul style="list-style-type: none">■ Robot automatically pauses the protocol for a defined amount of time■ Enter a duration and a message to display
Pause until temperature reached	<ul style="list-style-type: none">■ Robot automatically pauses the protocol until a module reaches a defined temperature■ Select the module, temperature in °C, and add a message to display

For each option, you can add a custom message to display on the Flex touchscreen or in the Opentrons App. Once a pause step is created, you can also rename the step to add more information.

Edit and finalize a protocol

After adding steps the robot will perform in your protocol, you can view or change the protocol timeline, edit steps, and fix any warnings or errors. This section describes editing and finalizing a newly created protocol in Protocol Designer.

PROTOCOL TIMELINE

Each step in your protocol appears in the protocol timeline in the order you've added them. Use the protocol timeline to preview the steps the robot will perform in your protocol. Hover over each step to view a description of the step and changes to the robot deck, like labware moves or liquid transfers.

EDITING STEPS

To view or edit a step in your protocol timeline, start by clicking on the step. For the transfer step shown below, hover or click on the step to view a step description, including transfer volume and source and destination labware locations.

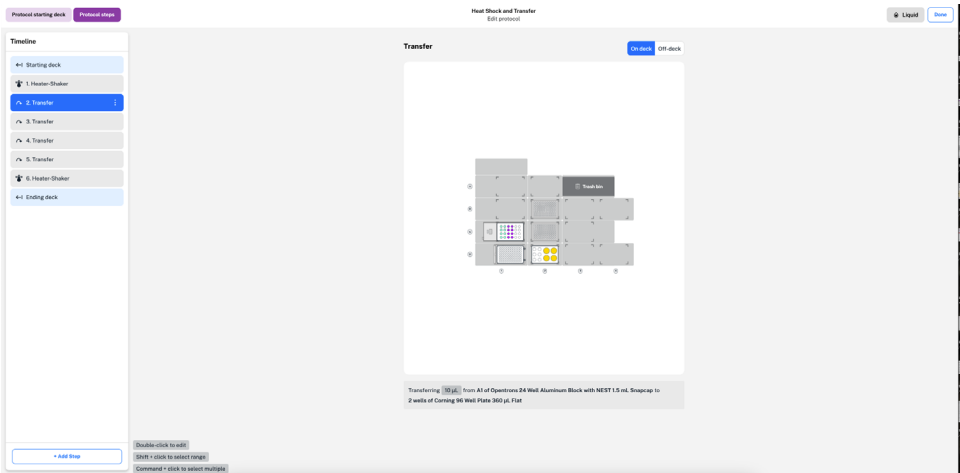

To edit, double click the step in the protocol timeline. This opens the same step form used when adding a step. At the top right of the form, click **Rename** to give steps a custom name and description. The step name is displayed in the Opentrons App during your protocol run.

Use the three-dot menu at the right side of each step in the protocol timeline to access more step options. Here, you can edit the step or view more details, if available.

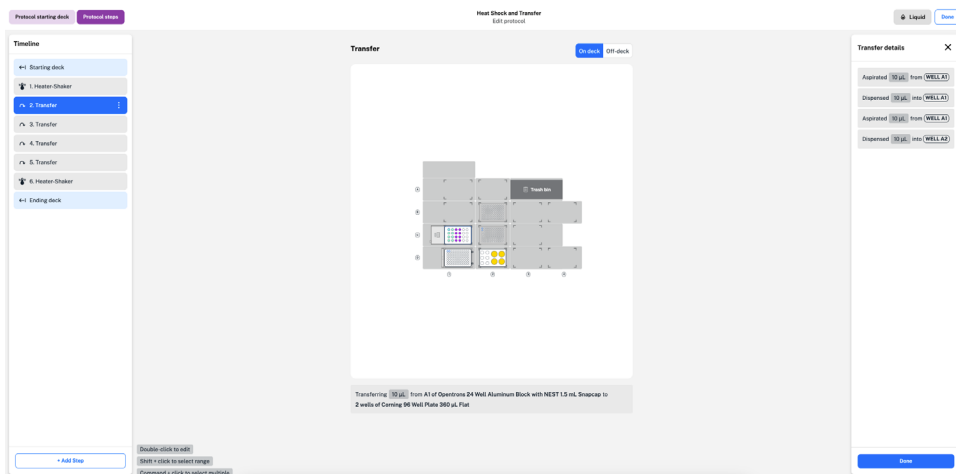

In the same transfer step, step details include each single-path aspirate and dispense motion required to add 10 µL of a DNA sample to wells A1 and A2 of a Corning 96-well plate in the Heater-Shaker Module. Step details can also show mix wells and repetitions for a mix step, or steps and cycles of a Thermocycler Module profile.

To edit multiple transfer steps of the same type, use the shift or command key and click to select. Selecting multiple transfer steps allows you to batch edit aspirate and dispense flow rate, well order, tip position, and other advanced settings.

Steps in your protocol timeline initially appear in the order you've added them. To change the step order, click and drag to move a single step in the protocol timeline. You can only reorder one step at a time. Changing the step order can cause protocol errors, so Protocol Designer will ask you to confirm your change each time.

WARNINGS AND ERRORS

To prevent errors, Protocol Designer displays hints, warnings, and error descriptions as you create a protocol. This section covers types and causes of warnings and errors in Protocol Designer.

Warnings

Warnings in Protocol Designer alert you to a potential problem with a protocol step. In the example below, 4 source wells have been selected for a liquid transfer to 16 destination wells. Protocol Designer includes a warning in the transfer step form because this well selection, or ratio of source to destination wells, isn't allowed.

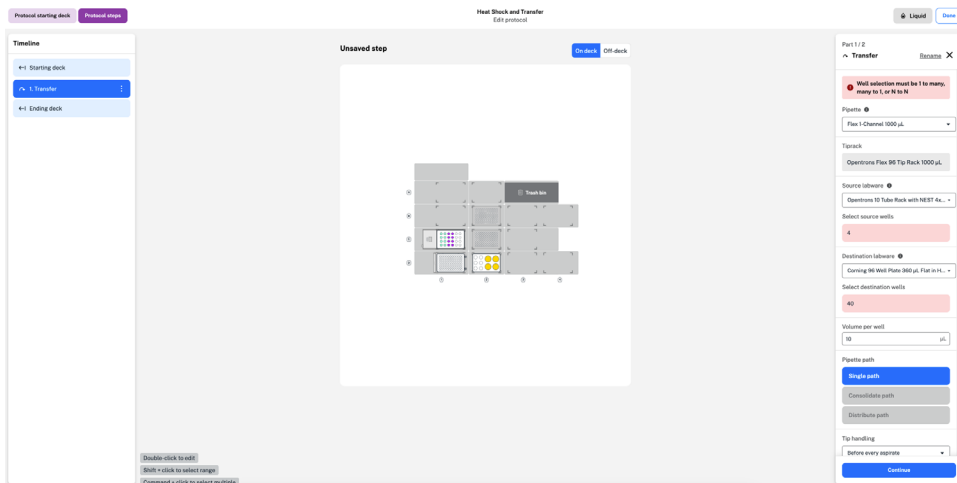

The step warning appears in a red text box at the top of the step form. In most cases, the warning includes a description of the issue or action needed to resolve the warning. To quickly resolve this step warning, change the well selection to just one source or destination well.

In some cases, a step warning appears after creating a step. If a transfer step aspirates more liquid than is available in the source well, a step warning is included only after the step has been saved and analyzed by Protocol Designer. To view and resolve the warning, double-click the step to reopen the form and edit.

Many step warnings shown by Protocol Designer will not affect the function of your protocol steps. You can save and run a protocol on the robot with these warnings present. For example, the robot can still aspirate and dispense your chosen amount of liquid, even if it overflows a destination well. We recommend resolving all warnings to avoid problems in your workflow.

Errors

A protocol error represents a larger problem in the protocol timeline. Although you can save, download, and import your protocol into the Opentrons App, a protocol with an error cannot be run on the robot and will cause a run to fail.

A protocol error appears in a red text box above the deck map and, like a warning, includes a description of the error and required action to resolve it. Most errors in Protocol Designer are caused by the order of steps or changes to the protocol timeline. Any labware, liquids, or modules that you edit or delete on the protocol starting deck can also cause errors for each protocol step they are used in.

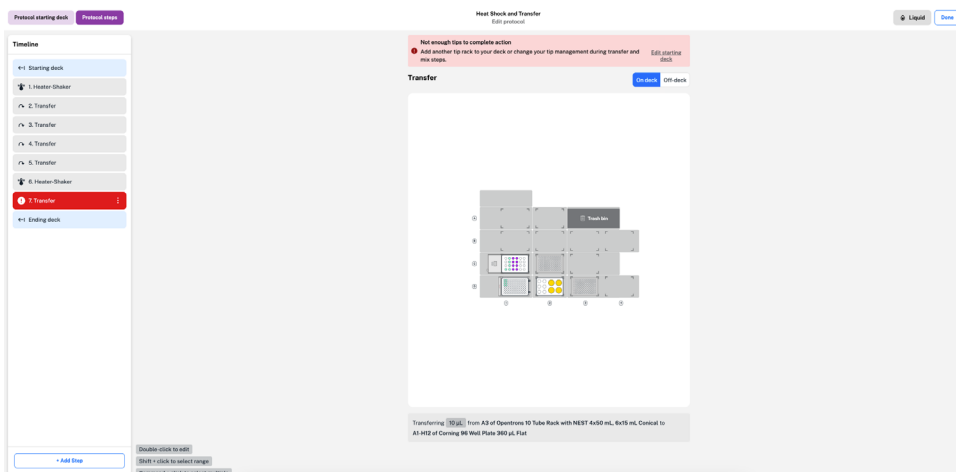

In this example, not enough tips are available on the deck to complete the number of transfers. Because the robot cannot complete the protocol as is, Protocol Designer displays a protocol error. To resolve this error, add more tips to the protocol starting deck or change tip management, or tip handling, settings in the transfer step form.

When designing your protocol, consider the order the labware and modules should interact in to avoid protocol errors.

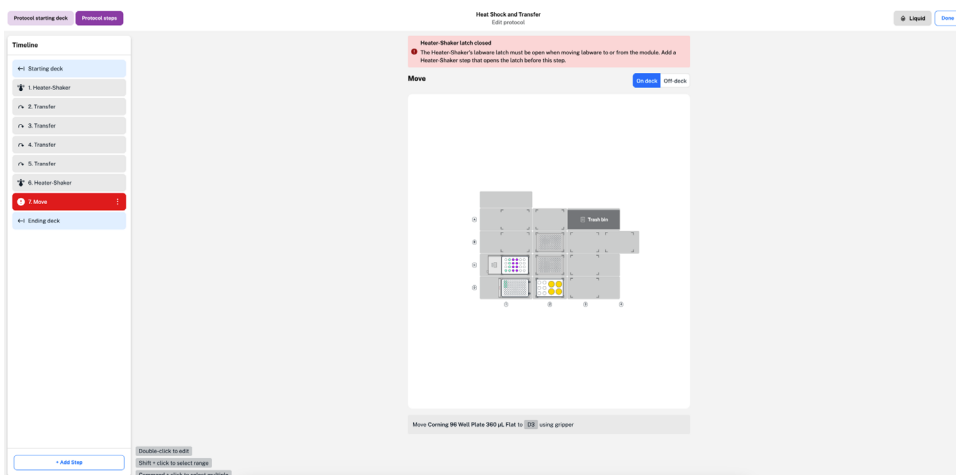

Export protocol

When you're finished creating and editing your protocol, click Done in the upper right to return to the protocol overview. Click Export protocol to download your protocol as a JSON file.

If your protocol contains unused hardware or labware, Protocol Designer will ask if you'd like to remove it before exporting the protocol.

Modify an existing protocol

You can upload and edit protocols you have previously made in Protocol Designer. On the starting screen, click Edit existing protocol and upload your Protocol Designer JSON file. Your protocol details will be visible in the protocol overview. Click Edit protocol to make your desired changes.

When uploading a JSON file created in a previous version of Protocol Designer, the protocol will be automatically updated to the latest version. The updated JSON file will be incompatible with previous Protocol Designer and Opentrons App versions.

We recommend making a separate copy of your protocol before importing and editing.

If you edit an exported JSON file in a text editor outside of Protocol Designer, errors could occur when re-uploading. JSON files created outside of Protocol Designer aren't supported.

Protocol Designer settings

Click the settings icon in the top right to access Protocol Designer settings. You can access this software manual and view release notes in the App Info links.

Protocol Designer shows hints, tips, and timeline editing suggestions to help you fix protocol warnings and errors. You can restore all hints and tips shown during protocol editing and toggle timeline editing guidance on and off.

You can choose to share analytics with Opentrons to improve Protocol Designer and other services. To report a Protocol Designer bug, contact Opentrons Support at support@opentrons.com.



Post-sales service & contacting Opentrons

If you have any questions about the use of the system, abnormal phenomena, or special needs, please contact: support@opentrons.com. Also visit www.opentrons.com.